

Rotation & Torque

Disc A (mass 5.0 kg, radius 15.0 cm) is turned by a constant 3.0 N force that is applied 20.0 cm away from the pivot point, perpendicular to the lever arm. The arm has a mass of 0.5 kg, length 20.0 cm and is attached to the center of the disc.

- a. What is the torque on the disc due to the applied force?
- b. What is the moment of inertia for the disc-bar combination?
- c. What is the angular acceleration for the combination?
- d. What is the angular velocity of the system after 5 seconds (assume they are initially at rest)?

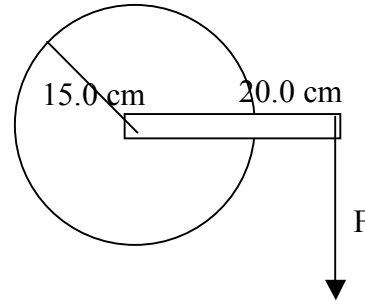

Disc B (mass 3.0 kg, radius 10.0 cm) is now added to the combination by a rope. The tension in the rope is negligible in the bottom section of the rope.

- e. What would the angular acceleration be for the back disc if the front had the same acceleration as above?
- f. What torque is needed on the back disc to produce this acceleration?
- g. What is the tension in the top section of the rope?
- h. What is the net torque on the front disc-rod combination?
- i. What force would you need to apply?

